

W3-Series Fertigation System



General Description:

The W3-Series consists of one metering pump available in six different sizes, driven by an integral proportional control system. This system is designed to be furnished with a Data Industrial model 220 flow sensor, or using the on board opto-isolator, can be slaved off of the sensor on a package pump station. The pump is motor driven and controlled using the latest VFD technology. This system was created to be a simple, economical solution for reliable proportional injection. In the base model, the proportional rate is set simply by adjusting the knobs on the pump. If more features are desired, you can purchase the optional Pocket Watcher™ software package, and access the onboard computer with an ordinary Palm™ PDA. With the Pocket Watcher software, you have access to many of the features of our larger systems, such as time and date settings, direct PPM rate setting, water and product usage logs, and several others. The system is ideal for grow-in applications and for those who want a simple yet state-of-the-art system on a limited budget.

Features

- Liquid end is compatible for use with all fertilizer materials.
- The unit is mounted on a rugged stainless steel frame.
- Pre wired and plumbed for easy installation.
- High efficiency VFD design.
- Simple to operate and maintain.
- Made in the USA.

WERECON Inc.

3320 N. 29th Ave. / Phoenix, AZ 85017 / 1-888-WERECON / www.werecon.com

W-3 Series Technical Information

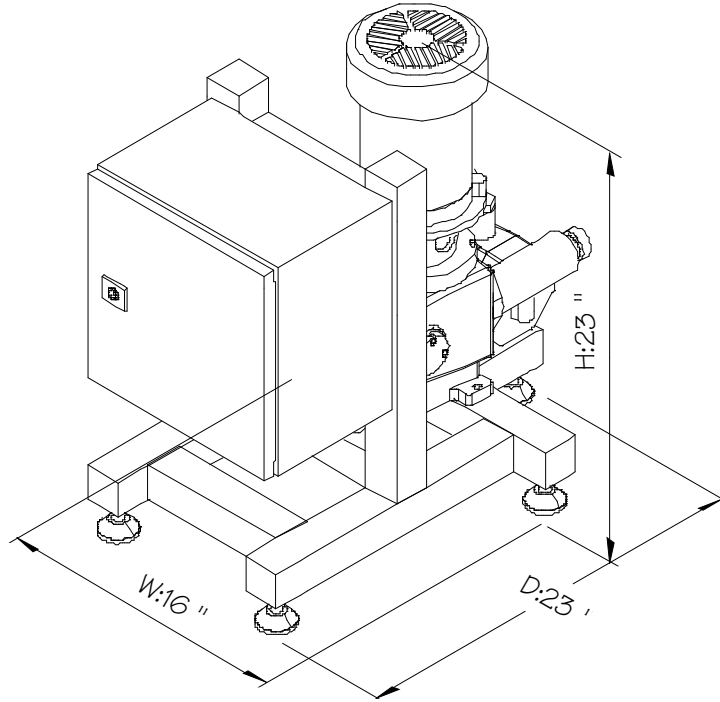

Specifications

Dimensions	16W x 23D x 23H
Frame Construction	304 Stainless Steel
Diaphragm	PTFE
Liquid end	Alloy 20
Seals	Viton A
Check valves	Alloy 20
Motor Type	230/480 3 phase provided by on board VFD.
Input Power	110-120VAC 1phase at 10 AMP
Pump capacity	18, 22, and 30 GPH simplex or duplex
Pressure max.	350psi 1.7 Bar
Weight	120 lbs

Pre wired power cordset for standard 120VAC Outlet.

WERECON Inc.

3320 N. 29th Ave. / Phoenix, AZ 85017 / 1-888-WERECON / www.werecon.com