

W4-Series Fertigation System



General Description:

The W-4 series consists of one to three metering pumps available in seven sizes, driven by our exclusive Green Scorpion™ control system. The system is designed to be used with a all types of liquid fertilizers. The pump is motor driven and controlled using the latest VFD technology. The control system operates the pump and allows for simple rate programming, while keeping track of product usage and tank levels. The system runs proportional to flow and is ideal for Golf Course use. For more details on the control system used with this unit, please refer to our publication on the WCM-GS Green Scorpion™ Control system.

Features

- Liquid end is compatible for use with all fertilizer materials.
- The unit is mounted on a rugged stainless steel frame.
- Pre wired and plumbed for easy installation.
- High efficiency VFD design.
- User friendly controls.
- Expandable (More Pumps, PC Control, etc.)
- Made in the USA.

WERECON Inc.

3320 N. 29th Ave. / Phoenix, AZ 85017 / 1-888-WERECON / www.werecon.com

W-4 Series Technical Information

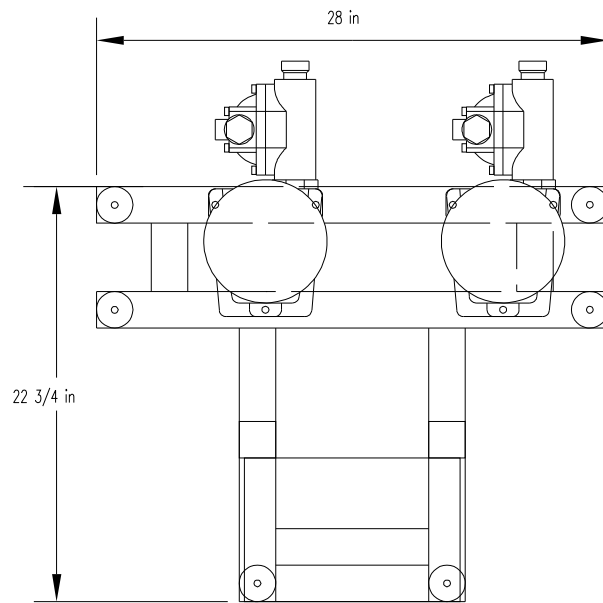

BASE CHASSIS DRAWING - ACTUAL LAYOUT MAY VARY.

Typical Specifications

Dimensions	28" X 28" X 32"
Frame Construction	304 Stainless Steel
Diaphragm	PTFE
Liquid end	Alloy 20
Seals	Viton A
Check valves	Alloy 20
Motor Type	230/480 3 phase provided by on board VFD.
Input Power	110-120VAC 1phase at 10 AMP
Pump capacity	5.4, 18, 22, or 30 GPH
Pressure max.	150PSI (5.4 size) 350PSI (all others)
Weight	approx. 135 lbs

Pre wired power cordset for standard 120VAC Outlet.

WERECON Inc.

3320 N. 29th Ave. / Phoenix, AZ 85017 / 1-888-WERECON / www.werecon.com